

17. CONCRETE 500 DRAWINGS

TABLE 1

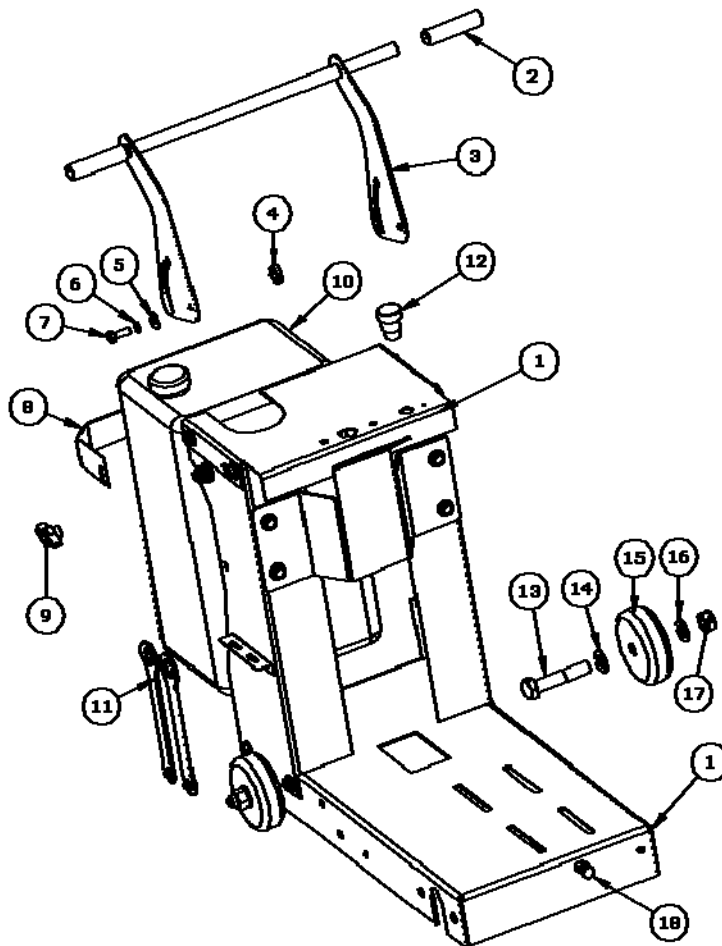

Table 1. Components

N°	NAME	N°	NAME
01/1.	Chassis	10/1.	Water tank 30 l.
02/1.	Handlebar grip	11/1.	Keys
03/1.	Handlebar	12/1.	Emergency push button
04/1.	Nylon separator	13/1.	Bolt DIN.931 M-20x90
05/1.	Washer DIN.9021 Ø10 mm	14/1.	Washer DIN-125 Ø20 mm
06/1.	Washer DIN.127 Ø10 mm	15/1.	Back Wheel
07/1.	Screw DIN.933 M-10x30	16/1.	Washer DIN.125 Ø20 mm
08/1.	Fastening water tank	17/1.	Nut DIN.934 M-20
09/1.	Butterfly nut M-10	18/1.	Tensioner

TABLE 2

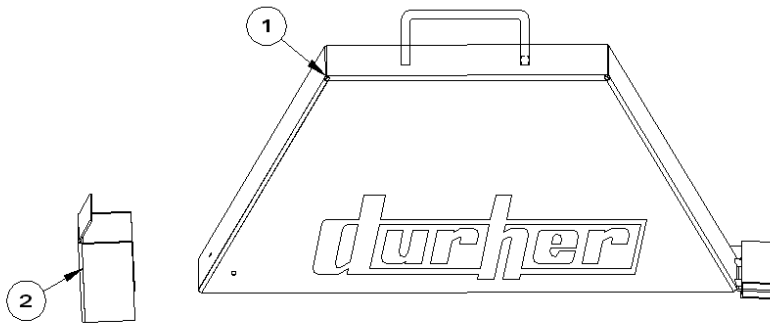

Table 2. Components

N°	NAME	N°	NAME
01/2.	Housing	02/2.	Housing rubber

TABLE 3

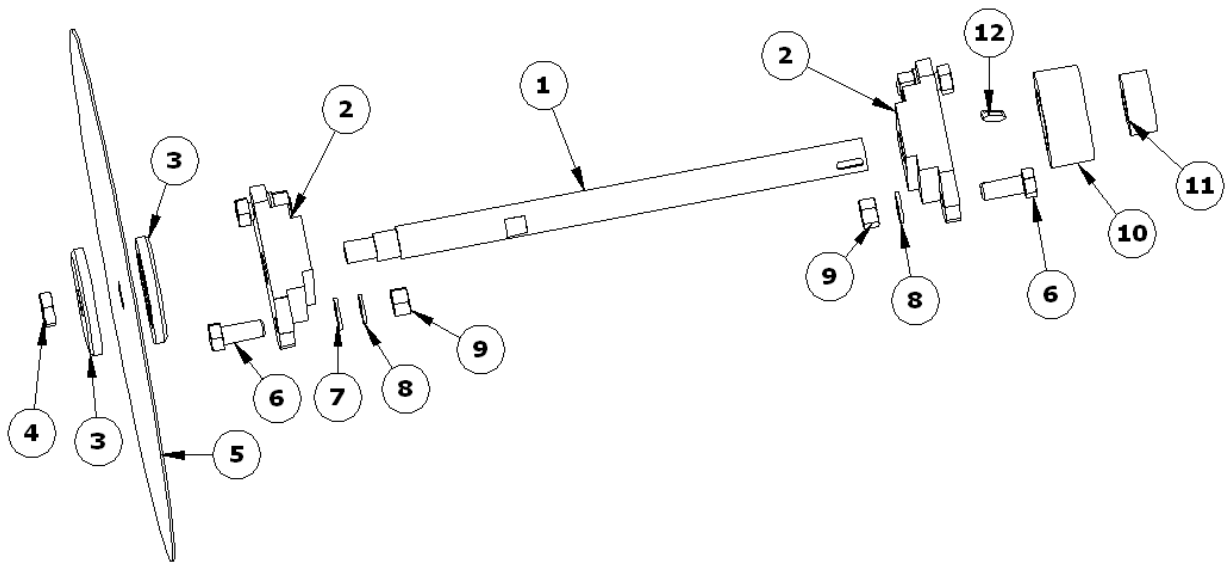

Table 3. Components

N°	NAME	N°	NAME
01/3.	Blade shaft	07/3.	Washer DIN.125 M-16
02/3.	Bearing for the blade shaft	08/3.	Washer DIN.127 M-16
03/3.	Plate	09/3.	Nut DIN.934 M-16
04/3.	Nut for the blade shaft	10/3.	Blade shaft pulley
05/3.	Blade	11/3.	Blade shaft taper
06/3.	Screw DIN.933 M-16x45	12/3.	Blade shaft wedge

TABLE 4

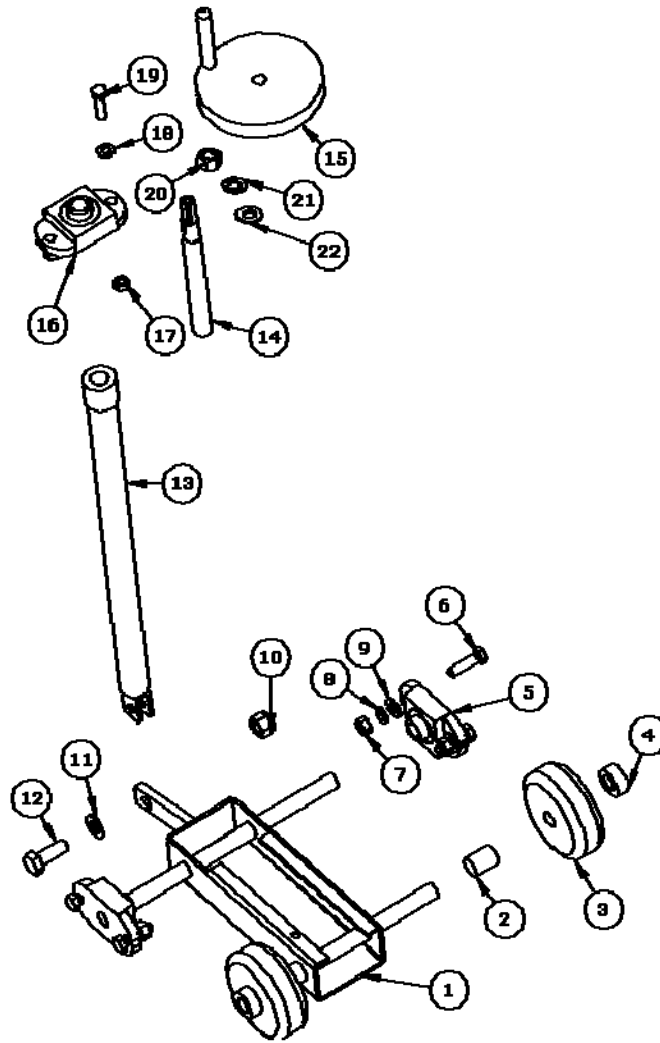

Table 4. Components

N°	NAME	N°	NAME
01/4.	Skate	12/4.	Screw DIN.933 M-16X45
02/4.	Wheel collar	13/4.	Spindle house
03/4.	Skate wheel	14/4.	Spindle
04/4.	Fastening wheel collar	15/4.	Handwheel
05/4.	Spindle and skate Bearing	16/4.	Spindle and skate Bearing
06/4.	Screw DIN.933 M-12x40	17/4.	Nut DIN.934 M-10
07/4.	Nut DIN.934 M-12	18/4.	Washer DIN.125 M-10
08/4.	Washer DIN.127 M-12	19/4.	Screw DIN.933 M-10x40
09/4.	Washer DIN.125 M-12	20/4.	Nut DIN.1587 M-16
10/4.	Nut DIN.985 M-16	21/4.	Washer DIN.127 Ø16 mm
11/4.	Washer DIN.125 M-16	22/4.	Nut DIN.934 M-16

TABLE 5

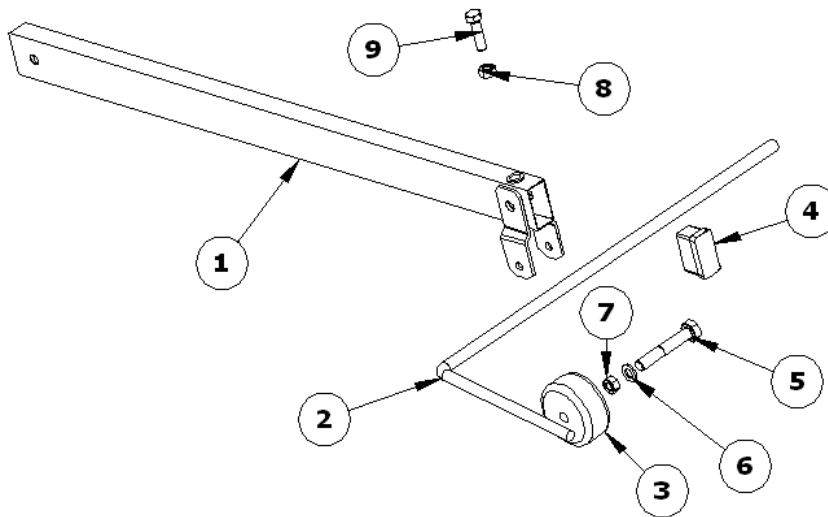

Table 5. Components

N°	NAME	N°	NAME
01/5.	Spear guide	06/5.	Washer din.125 Ø10 mm
02/5.	Cutting guide	07/5.	Nut DIN.985 M-8
03/5.	Guide wheel	08/5.	Nut DIN.934 M-8
04/5.	Plastic plugs	09/5.	Screw DIN.933 M-8x25
05/5.	Screw DIN.933 m-8X50		

TABLE 6

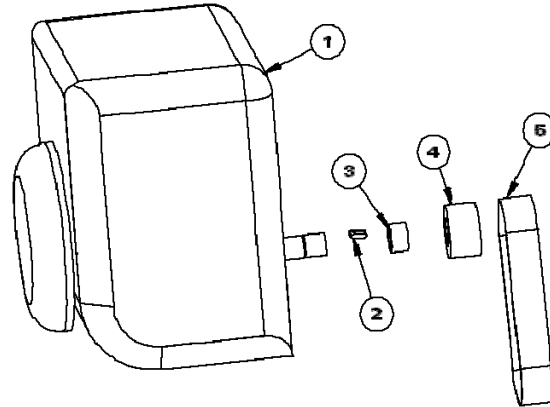

Table 6. Components.

N°	NAME	N°	NAME
01/6.	Motor	04/6.	Motor pulley
02/6.	Blade shaft wedge	05/6.	Belt
03/6.	Motor taper collar		

TABLE 7

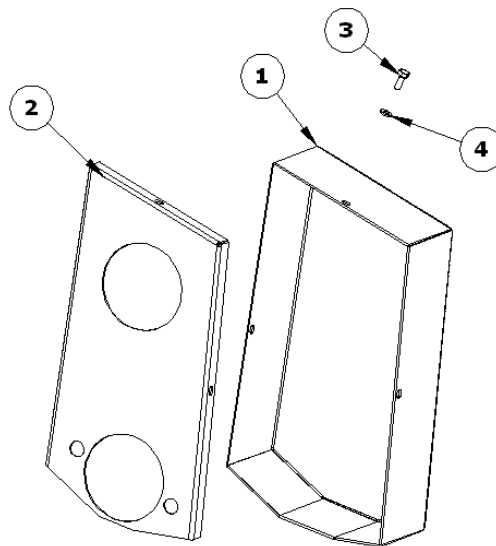

Table 7. Components.

N°	NAME	N°	NAME
01/7.	External belt housing	03/7.	Screw DIN.933 M-6x16
02/7.	Internal belt housing	04/7.	Nut DIN.125 Ø10 mm

TABLE 8

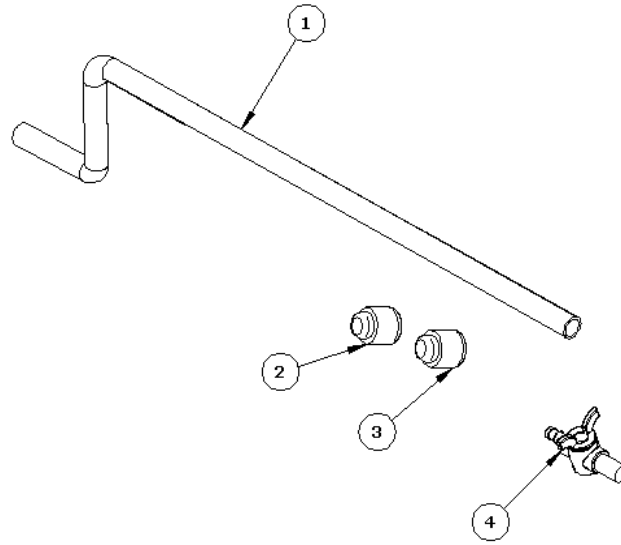

TABLE 8. Components.

N°	NAME	N°	NAME
01/8.	Cooling system	03/8.	Connector
02/8.	Fast plugging	04/8.	Cock