

9. Spare parts

Scarifying head JAVALÓN

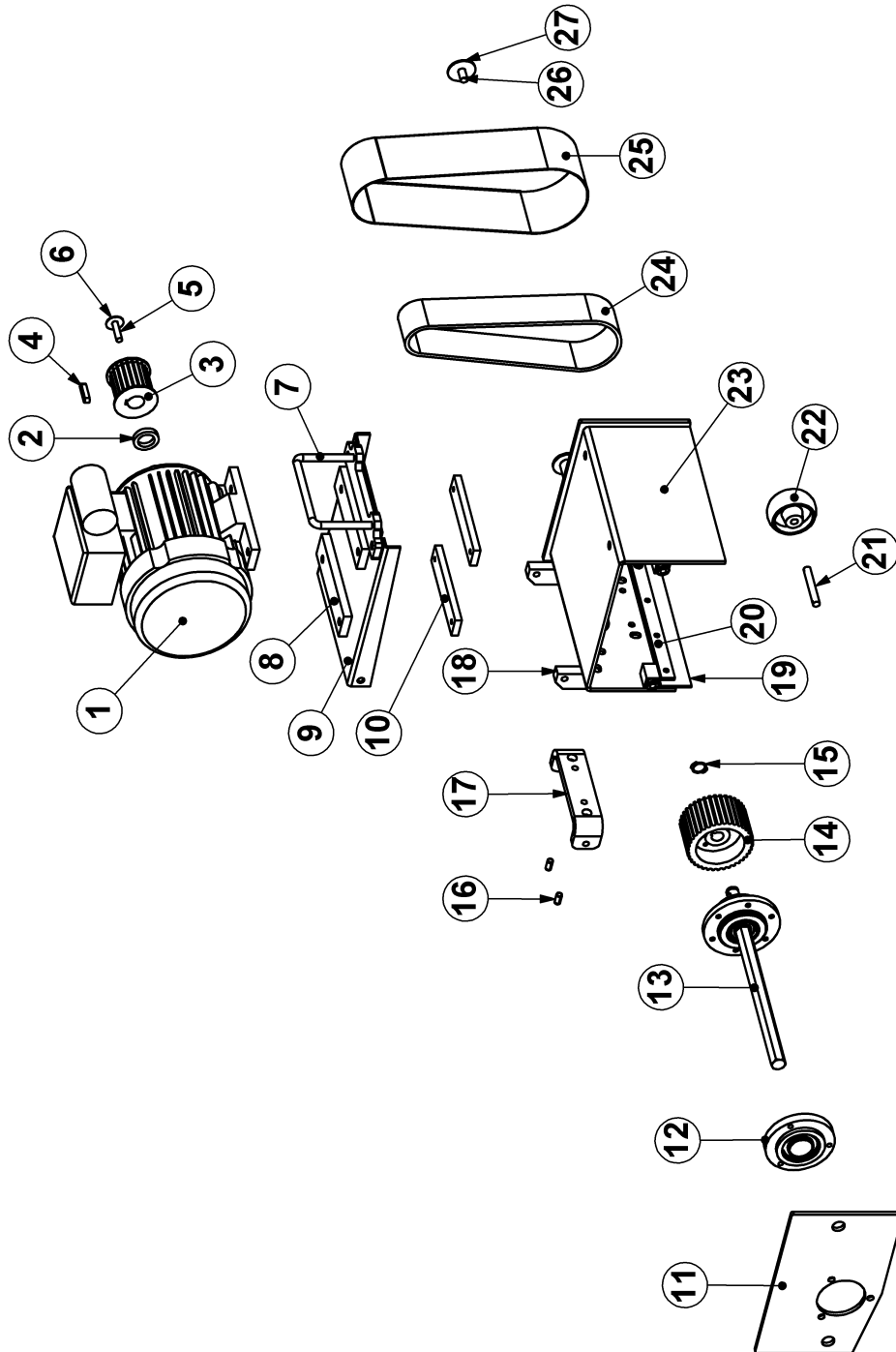

Scarifying head JAVALÓN

Item	Description	Qty.
1	Electro motor JAVALÓN 230V/50Hz	1
	Electro motor JAVALÓN 110V/50Hz	1
	Electro motor JAVALÓN 400V	1
2	Spacer ring	1
3	Top pulley	1
4	Parallel key 8x7x35	1
5	M8x35 bolt	1
6	M8 washer Ø35	1
7	Handle	1
8	Clamping bar	2
9	Motor base plate	1
10	Clamping bar	2
11	Side plate only	1
12	BU complete	1
13	BU complete	1
14	Bottom pulley	1
15	Circlip Ø17	1
16	Spring type straight pin Ø8x16	2
17	Wheel balance holder	1
18	Hinge plate	2
19	Rubber gasket	1
20	Clamping bar	1
21	Axle	1
22	Wheel	1
23	Housing	1
24	Belt	1
25	Belt guard	1
26	M10x20 bolt	1
27	M10 washer Ø40	1

Bearing unit right

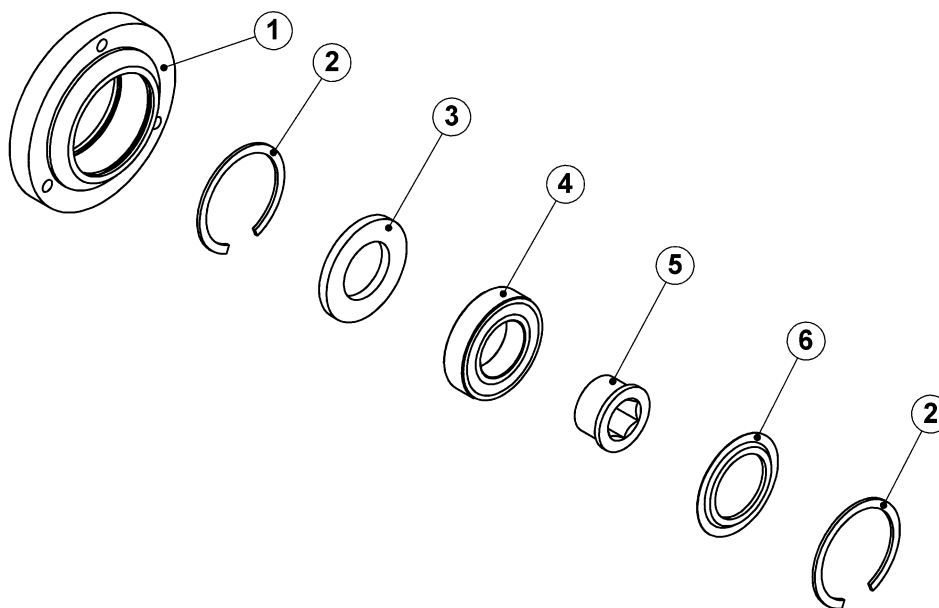

Item	Description	Qty.
1	Bearing housing	1
2	Circlip Ø55	2
3	Cover	1
4	Bearing	1
5	Hexagon driving support	1
6	Protection ring	1

Bearing unit left

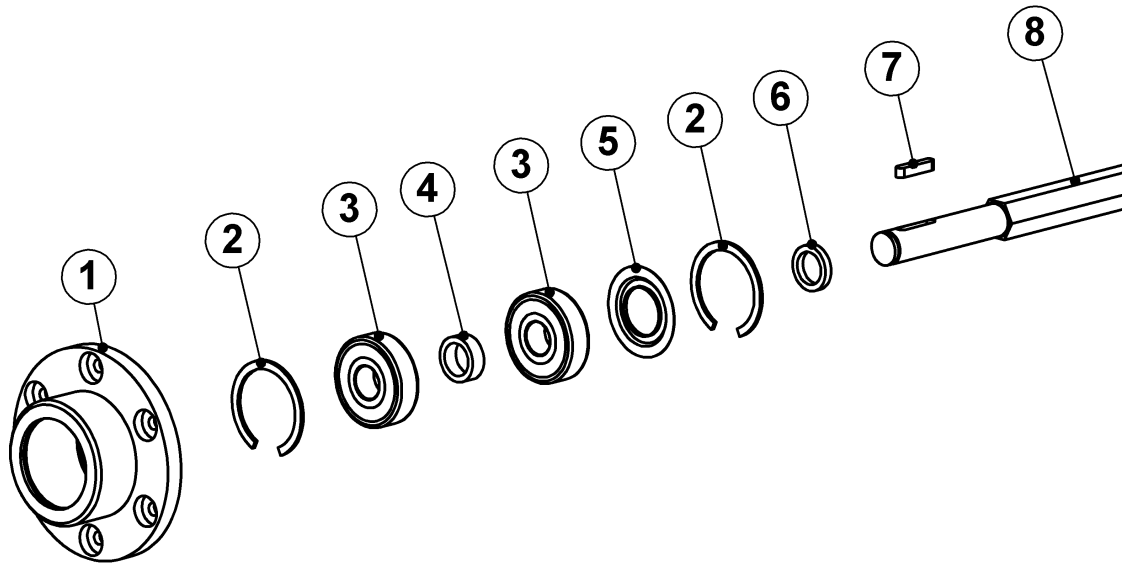

Item	Description	Qty.
1	Bearing housing	1
2	Circlip Ø47	2
3	Bearing	3
4	Distance bush	1
5	Protection ring	1
6	Distance ring	1
7	Parallel key 5x5x25	1
8	Hexagon drive shaft	1

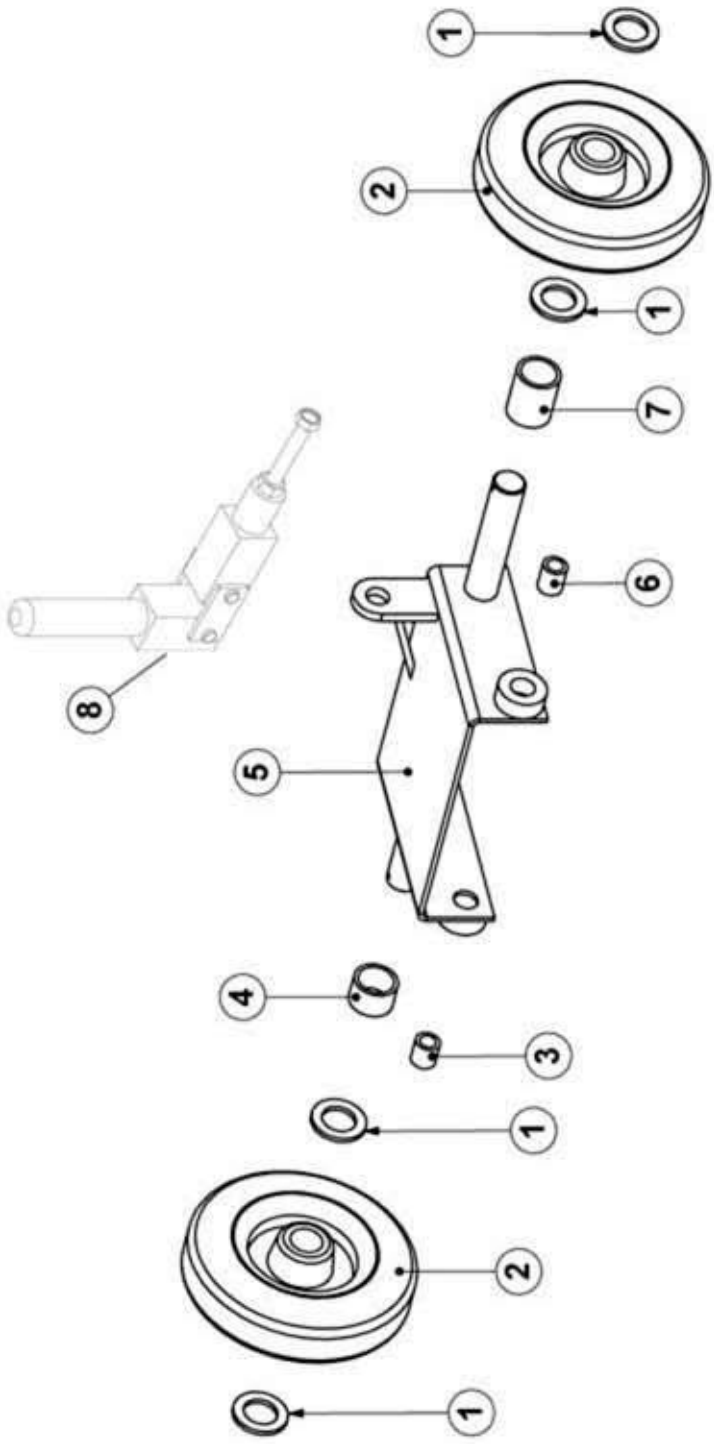

Wheel bracket

Item	Description	Qty.
1	M20 washer	4
2	Wheel	2
3	Bushing	1
4	Bushing	1
5	Wheel bracket	1
6	Bushing	1
7	Bushing	1
8	Brake	1

Spindle

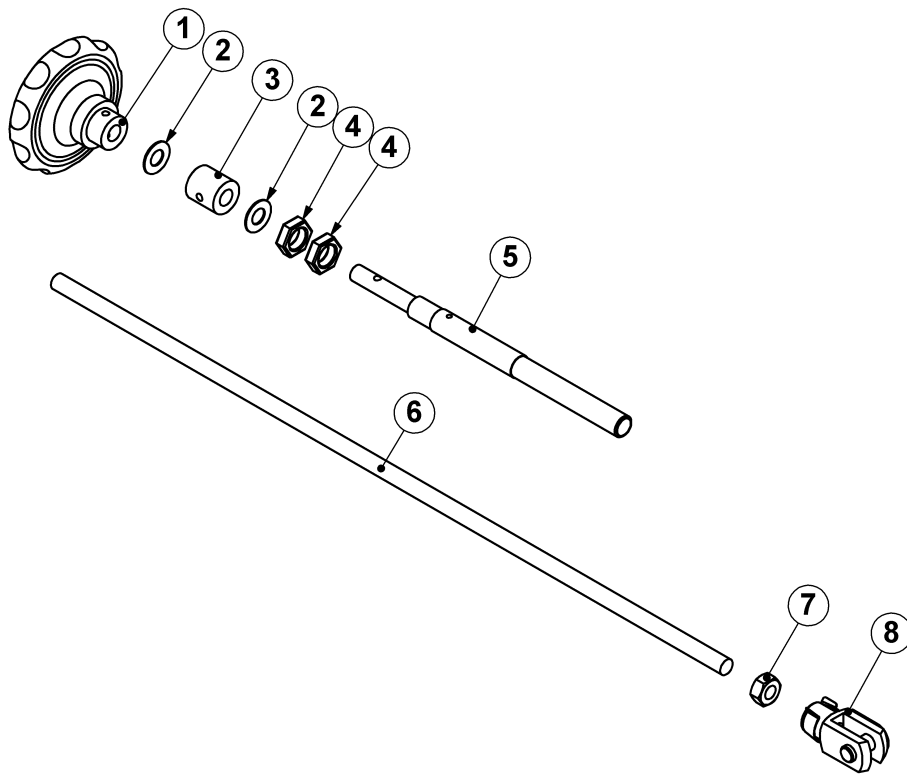

Item	Description	Qty.
1	Handwheel	1
2	Shim Ø12x24x1	2
3	Cylinder	1
4	M16 thin nut	2
5	Spindle sleeve	1
6	Threaded end	1
7	Nut M12	1
8	Fork joint 12x24	1

Handle complete

Item	Description	Qty.
1	Machine guide bar	1
2	Elektro kit 230V/50Hz	1
	Elektro kit 110V/50Hz	
	Elektro kit 400V	1
3	Lift handle complete	1
4	Grip rubber	2
5	Adapter	1

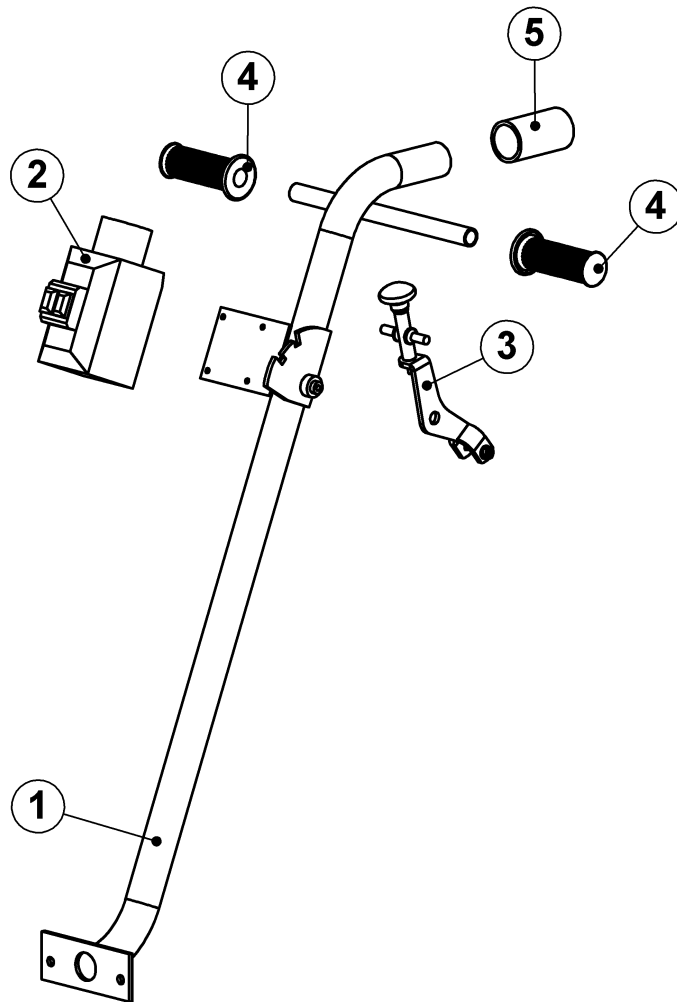

Lifting handle

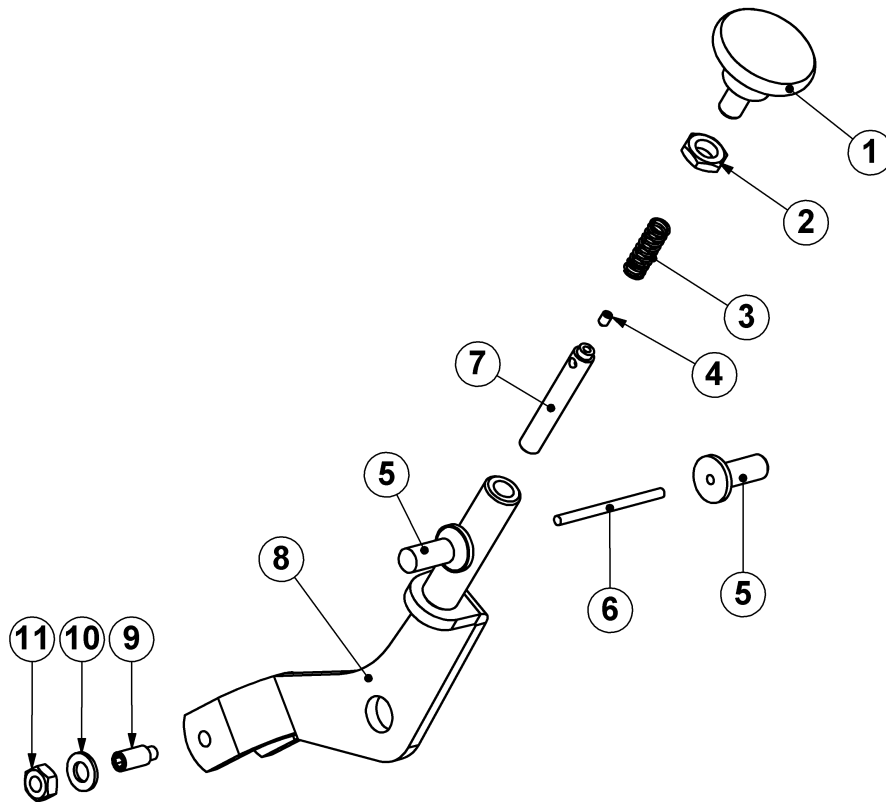

Item	Description	Qty.
1	Knob	1
2	M10 nut thin	1
3	Spring	1
4	M4x6 hexagon socket set screw with cup point	1
5	Finger grip	2
6	Shaft for finger knob	1
7	Fixation pin	1
8	Lift handle	1
9	M8x20 set screw with dog point	2
10	M8 washer	2
11	M8 nut	2

Drum complete

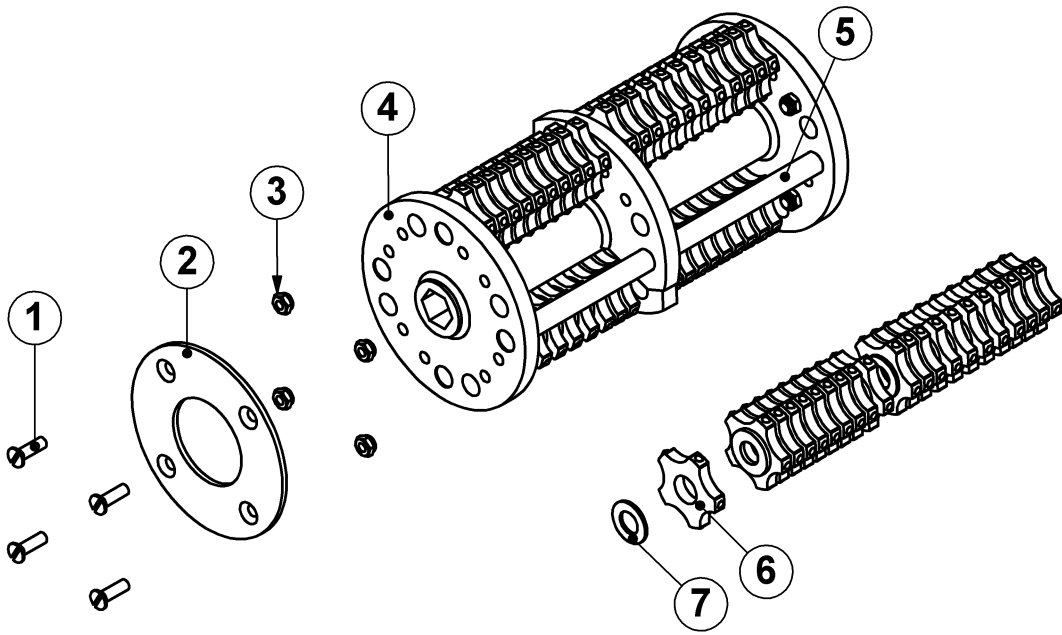

Item	Description	Qty.
1	M6x20 countersunk head screw	8
2	Retaining plate	2
3	M6 plastic insert nut	8
4	Drum	1
5	Drum axle 12mm for JAVALÓN	4
6	Cutter 5pt. 16x44x6 / 8.3 tc	76
7	Spacer ring SR25	108
	Spacer ring (ZS) 13x24x1,5 mm	8
1 - 5	Drum c/w strong /4x12mm.shafts	1
1 - 7	Drum cpl. with cutters(12mm.shafts)	1
6 - 7	Refill set cutters for JAVALÓN	1